

## 190787 Immersible Copper Sensor Instructions

### 1.0 OPERATION

The immersible copper sensor is designed for direct in-tank monitoring of electroless copper and microetch solutions. The sensor is compatible with WCU series controllers only; it is NOT compatible with Walchem W-10 series controllers. By monitoring the copper content directly in the solution, control lag and hydraulic problems are eliminated.

The sensor is constructed such that a constant path length exists between the fiber optic light guides. The ends of these light guides should NEVER be moved or adjusted. If moved, a "NEW SENSOR SETUP" is required. The solution between the guides absorbs light at specific wavelengths in proportion to the copper concentration. In order to avoid a shift in calibration caused by condensation, the sensor lid should NEVER be removed!

### 2.0 INSTALLATION

The immersible sensor is provided with a mounting plate and 20 feet of cable. Extension cable is available if the sensor can not be placed within 20 feet of the controller.

While positioning of the sensor is not particularly sensitive to the tank layout, the following suggestions are given to aid installation:

- Do not place the sensor beside heaters; if solution flow stops, the polypropylene guard may melt.
- Do not immerse the entire sensor, or the cable.
- Place the sensor where the loads of parts will not strike it.
- Place the sensor in an area of good solution movement, but not directly in the path of any air agitation.
- Mount the sensor securely to the rim of the tank using the holes provided. If the tank is rimless, use a block to provide the support for the mounting plate.

Attach the cable's connector to the WCU controller. The connector is keyed, do not force!

#### ***New Sensor Setup***

A "NEW SENSOR SETUP" must be performed through the controller if the sensor is a replacement to the original or the original sensor was sent back to the factory for repair. A "1-POINT CALIBRATION" should be sufficient for a sensor that was received with, and has the same serial number as a controller. Refer to the WCU Instruction Manual for additional information.

Press ENTER to set up a new sensor. First you see a warning message: "WARNING Chg sensor cal? N" This acts as a safety precaution for those who may only be "browsing" through the menus. If you enter the New Sensor Setup menu, you may easily, inadvertently, change the calibration of the sensor. If you continue with the following procedures, you must recalibrate the new sensor.

Water....xxxx.x

Place the immersible sensor in clean tap or DI water. When the number on the display is constant, press ENTER.

Sample....xxxx.x

Place the sensor in the bath at a known concentration. No work should be going through the bath so that the concentration remains constant. Ideally the bath should be at the typical operating copper concentration. When the number on the display is constant, press ENTER.

Smpl Conc

Use the arrow keys to change the displayed number to the actual concentration of the bath in grams/liter or ounces/gallon, depending on the unit of measure you have selected, then press ENTER.

### 3.0 MAINTENANCE

The sensor should be examined periodically for signs of plate-out or other coatings on the clear surfaces of the fiber optic light guides. To avoid scratching the sensitive surfaces, chemical cleaning is preferred over mechanical cleaning methods. Plate-out should be removed using nitric acid, or a persulfate or peroxide/sulfuric etch. Field repairs of the sensor should not be attempted. Call your distributor in order to arrange for factory service. Expedited service is available at no extra cost.

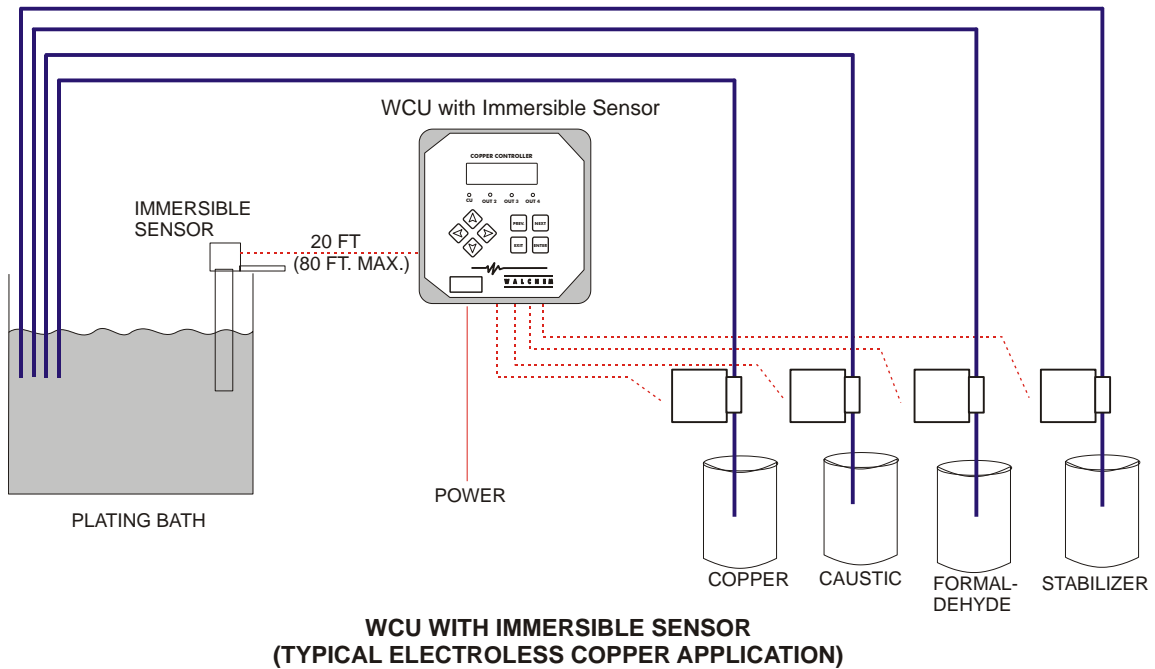

Note: To prevent calibration shifts due to condensation forming on the fiber optic light guides inside the cover of the sensor, DO NOT remove the sensor's cover for any reason!

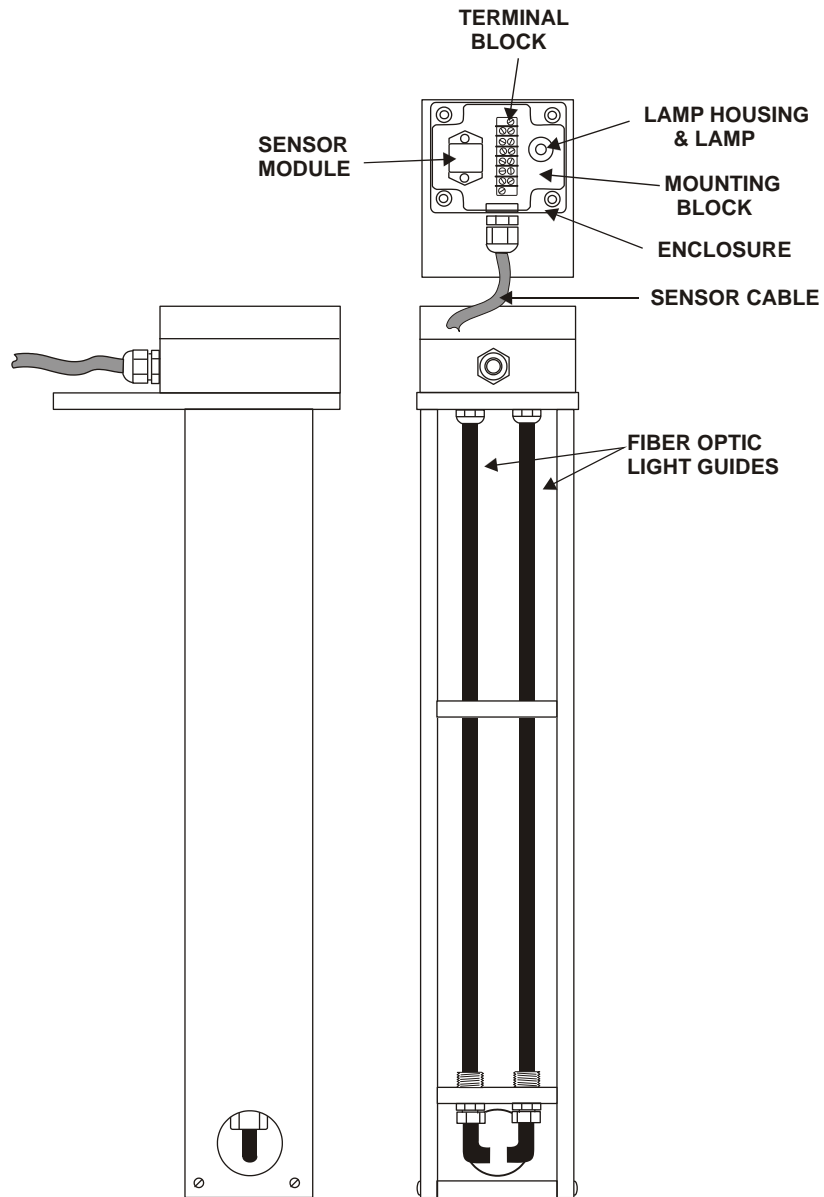

P/N 190787 WCU310 Series Immersible Copper Sensor